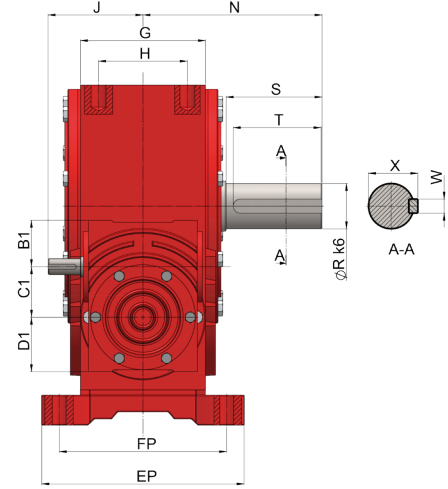
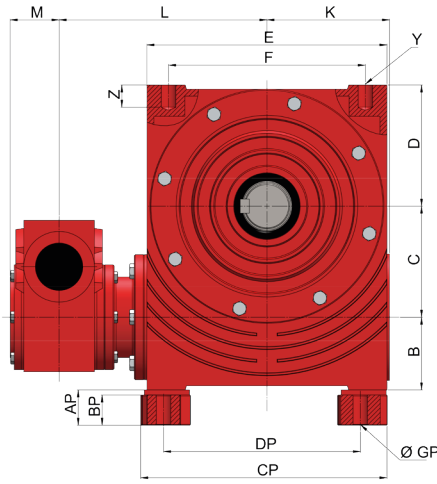
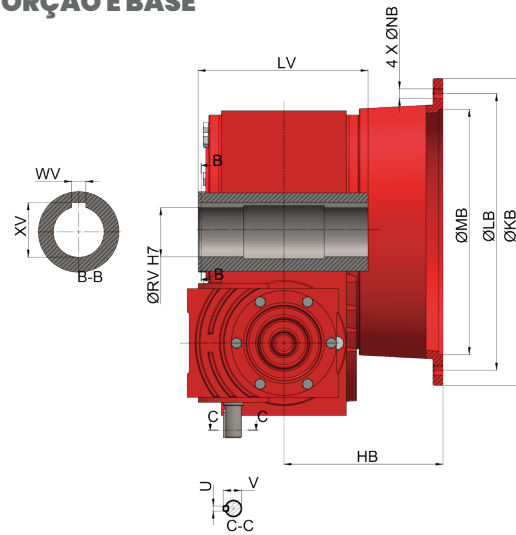
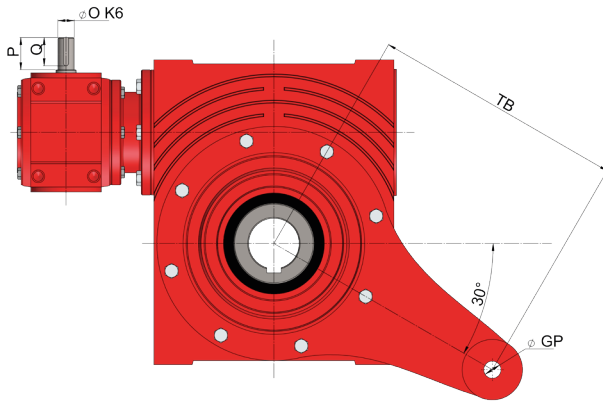

FIXAÇÃO CARCAÇA E PÉS

FIXAÇÃO BRAÇO DE TORÇÃO E BASE

TIPO	B	C	D	B1	C1	D1	E	F	G	H	J	K	M	N	ØO	P	Q	ØR	S	T	U	V
SD02	34	42	50	34	42	50	96	75	62	48	85	52	39	79	12	25	21	48	35	34	4	13,5
SD03	46	50	54	34	42	50	108	87	70	55	85	64	39	97	16	25	21	22	44	42	5	13,5
SD04	50	61	69	34	42	50	130	107	80	60	85	75	39	116	16	25	21	28	56	53	5	13,5
SD05	54	75	85	46	50	54	164	136	100	70	101	87	48	140	16	32	28	35	70	67	5	13,5
SD06	67	90	98	46	50	54	196	166	113	84	101	103	48	160	16	32	28	40	80	76	5	13,5
SD07	72	110	120	50	61	69	238	195	124	88	120	120	55	185	20	40	38	45	95	90	6	22,5
SD08	81	135	145	54	75	85	270	236	134	98	149	157	65	201	24	48	46	55	105	100	8	27

TIPO	W	X	Y	Z	AP	BP	CP	DP	EP	FP	ØGP	HB	ØKB	ØLB	ØMB	ØNB	ØRV	WV	XV	LV	TB
SD02	6	20,5	M8	12	13	10	100	80	105	85	9	68	140	120	100	9	16	5	18	85	85
SD03	6	24,5	M10	14	18	12	125	100	130	105	11	81	170	145	120	11	25	8	28	100	100
SD04	8	31	M10	14	18	12	145	120	145	120	11	93	195	170	140	11	30	8	33	115	145
SD05	10	38	M12	17	22	15	175	145	175	145	13	110	240	210	175	13	35	10	38	135	160
SD06	12	43	M12	17	23	15	207	175	190	160	13	119	270	240	205	13	45	14	48,8	150	180
SD07	14	48,5	M16	22	30	22	260	222	201	166	17	153	304	274	244	13	50	14	53,8	166	150
SD08	16	59	M16	22	33	22	303	266	212	176	17	171	374	334	295	16	55	16	59,3	180	300